

EBBEN & YORKE

Clearview Solution 500

STANDARD FEATURES

- Large Clearview double glazed door –
 - 8kW heat output -
- Hot air wash system for really clean burning -
- Independent up draft and down draft air distribution system for maximum response and control –
- Multi-fuel grate for easy lighting and response –
 - Rotary grate for easy riddling –
- Heavy steel construction, welded inside and out for durability and long life –
 - Stainless steel ash pan for easy ash removal –
- Optional top or rear 150mm (6 inch) diameter flue – - Adjustable hinges and door catch to maintain air tightness – - All wear and tear parts are easily removed and replaced making maintenance user friendly – - Solid brass knobs and door handles –

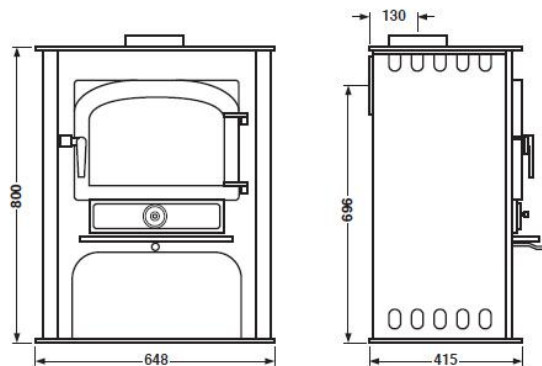

Ebben & Yorke
27 Mitchells
Weeford Road
Sutton Coldfield
B75 6NA
0121-308-0899
office@ebbenandyorke.co.uk