

EBBEN & YORKE

Clearview Pioneer 400

STANDARD FEATURES

- Large Clearview double glazed door -
- Hot air wash system for really clean burning -
- Independent up draft and down draft air distribution system for maximum response and control -
- Multi-fuel grate for easy lighting and response -
 - Rotary grate for easy riddling -
- Heavy steel construction, welded inside and out for durability and long life -
 - Stainless steel ash pan for easy ash removal -
 - Optional top or rear 150mm (6 inch) diameter flue -
- Adjustable hinges and door catch to maintain air tightness -
- All wear and tear parts are easily removed and replaced making maintenance user friendly -
 - Solid brass knobs and door handles -

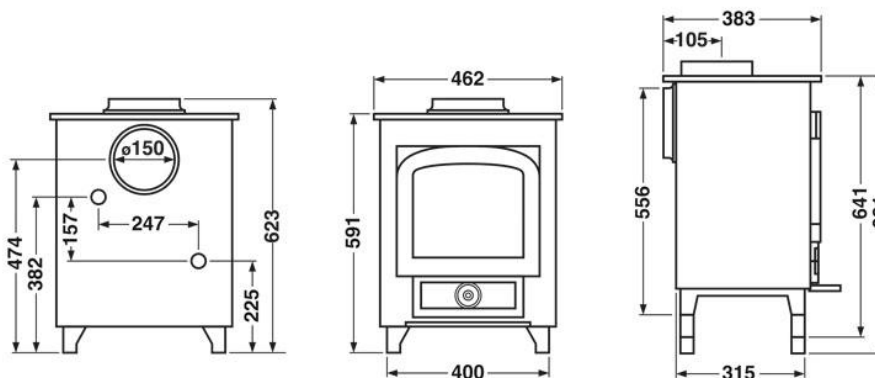

Ebben & Yorke
27 Mitchells
Weeford Road
Sutton Coldfield
B75 6NA

0121-308-0899
office@ebbenandyorke.co.uk